



TETA. Industrial Femtosecond Laser System

- One of the smallest laser heads in its class
- More than 2 mJ pulse energy
- <260 fs typical pulse duration
- >20 W average power at 1030 nm
- High beam quality with typical M2 <1.1
- 1030 / 515 / 343 / 248 nm possible outputs
- Monolithic thermally stabilized body
- Industrial and scientific application
- Excellent beam pointing and long term power stability
- Stand-alone operation and PC remote control software



TETA-10 laser head

Product overview

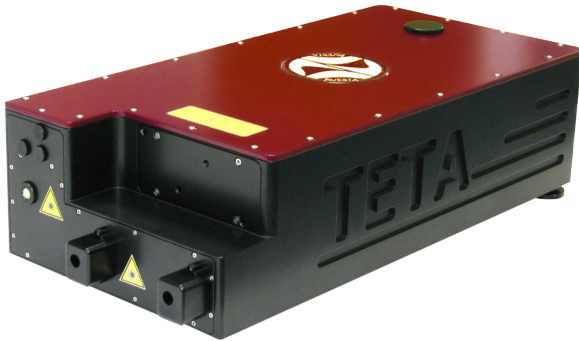

TETA system with integrated SH and FH units

The TETA is an Yb solid-state laser system. The system comprises a built-in fiber seed oscillator, fiber pulse stretcher, Faraday isolator, CPA-based regenerative amplifier with direct diode pumping, additional pulse picker and pulse compressor. All components are integrated into a single thermostabilized box ensuring stability and true turn-key operation. The additional built-in Pockels cell offers instant output radiation shuttering as well as total user control of output repetition rate. Moreover, the cell features precise pulse picking with control over the number of fired pulses (burst mode) and temporal period of radiation.

The TETA system may be equipped with a SH, TH and FH generation units, as well as with the Compulse capillary compressor which allows to bring the pulse duration down to 30 fs with >50% energy conversion efficiency.

Applications:

Time-Resolved Ultrafast Studies

Pump-Probe Spectroscopy

Conversion of Laser Radiation

Ultrafast OPA Pumping

Second Harmonic Generation (SHG)

Third Harmonic Generation (THG)

Fourth Harmonic Generation (FHG)

THz generation

Material and Biological Tissue Processing

Ultrafast Micromachining

Femtosecond Ablation

Cold Ablation Techniques

Photomask Repair Solutions

Laser Systems Design, Integration and Amplification

OPG Pumping

Front-End for TW- and PW-Class Femtosecond Amplifiers

OEM Integration

High-Energy Research

Free-Electron Laser (FEL) Seeding and Diagnostics



TETA-10 control 19" rack unit with on-board closed-loop chiller unit



AVESTA

LASERS AND OPTICAL SYSTEMS



Avesta Ltd., 11 Fizicheskaya Street
Troitsk, 108840, Moscow, Russia
Tel.: +7 (495) 967-94-73

fs@avesta.ru
www.avesta.ru

	TETA-3-HE	TETA-6	TETA-10	TETA-20
Max. average output power	3 W	6 W	10 W	20 W
Maximum pulse energy	>2 mJ	>400 μ J		>1 mJ
Min. pulse duration ¹⁾		<270 fs		<350 fs
Pulse duration tuning range ¹⁾		<270 fs - 10 ps		<350 fs - 10 ps
Central wavelength ²⁾ (fixed)		1033 \pm 3 nm		1030 \pm 3 nm
M ²		<1.15		<1.25
Beam diameter (at 1/e ²)	4.5 \pm 1 mm	3.2 \pm 0.5 mm		5 \pm 0.5 mm
Pulse repetition rate (user-adjustable)	single-shot...200 kHz (up to 1 MHz upon request)			
Pre- and post-pulse contrast	>5000:1			
Long-term output stability ³⁾	<0.5% rms over 48 h			
Output polarization	linear, vertical			
Spatial mode	TEM00			
Beam ellipticity ⁴⁾	<10%			
Beam astigmatism ⁴⁾	<10%			
Beam divergence (full angle)	<0.6 mrad			
Beam pointing stability	<25 μ rad/ $^{\circ}$ C			
Cold start warm-up time (beam position, output power)	<40 min			

Environmental and utility specifications

Operating temperature	15-30 $^{\circ}$ C			
Relative humidity	<60%, non-condensing			
Voltage	single-phase; 100-240 VAC; 50/60 Hz			
Power consumption	<1.5 kW			<2 kW

Physical dimensions

Laser head (LxWxH)	480x250x148 mm			550x350x148 mm
Control and power supply 19" rack (Wx-LxH)	553x600x663 mm			
Umbilical length	3 m			

1) - measured with Avesta's AA-10DD-12PS interferometric autocorrelator using Gaussian fitting; motorized tunable pulse duration with PC control up to 10 ps is also installed by default; the Compulse-1030 external hollow-fiber pulse compressor with output pulse duration down to 30 fs is also available as an option;

2) - upon request: second, third and fourth harmonic generators (or certain built-in combinations); OPA, DFG extensions; Raman shifters to 1530 nm and 1890 nm are also available;

3) - measured under stable environmental conditions;

4) - measured at maximum average power and 100 kHz output repetition rate.

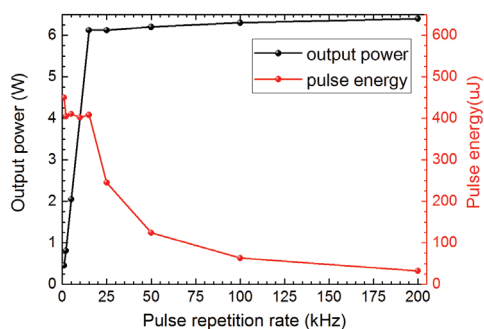

TETA-6

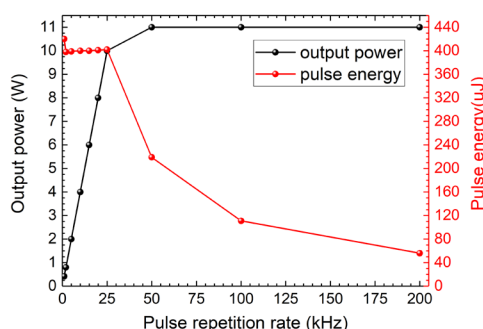

TETA-10

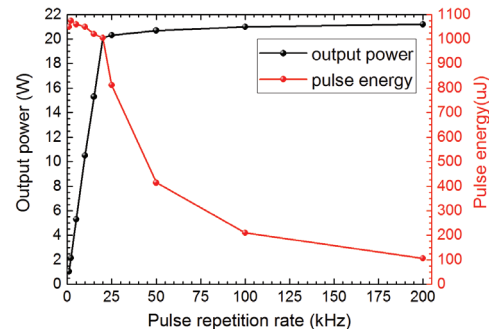

TETA-20

TETA output power and pulse energy vs. output repetition rate

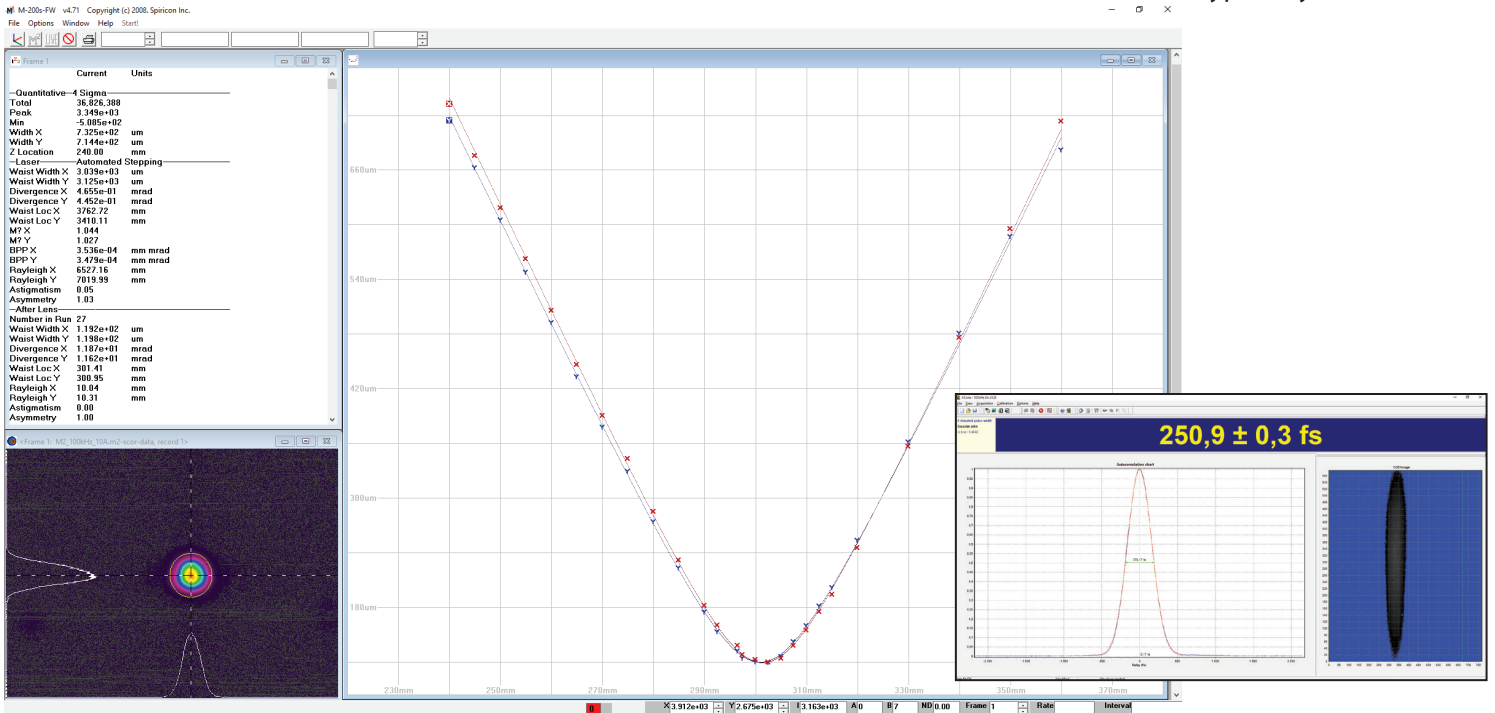

TETA typical M2 data and typical AC trace

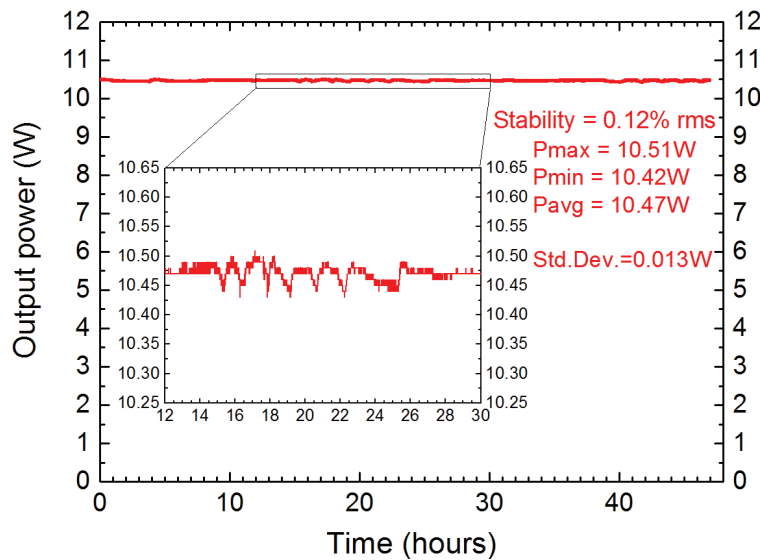

TETA-10 long-term power stability 48-hour run (0.12% rms)

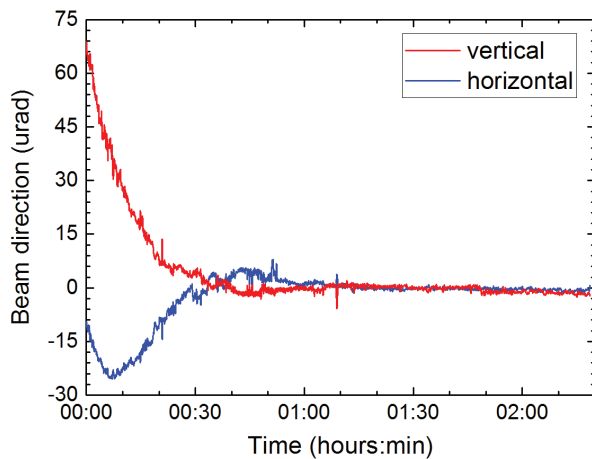

TETA beam direction after cold start

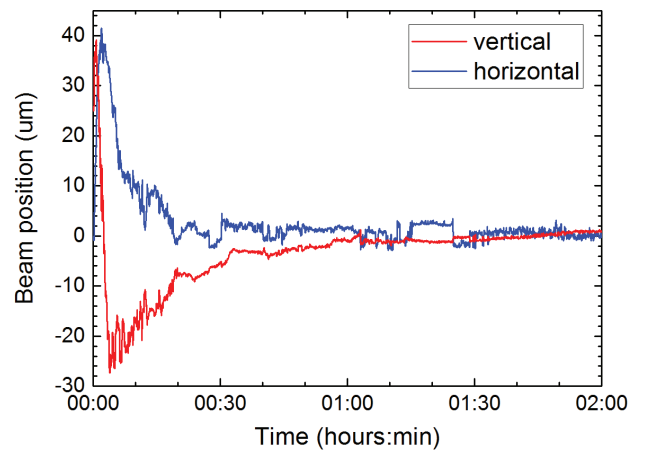

TETA beam position after cold start

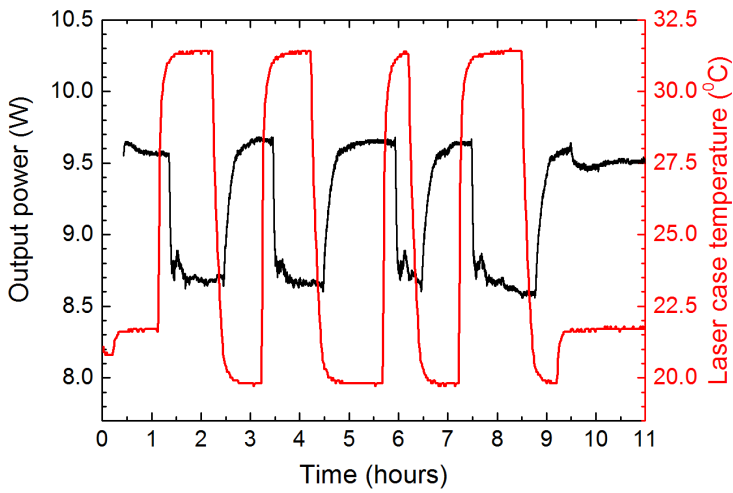

TETA-10 thermal cycling with large ΔT beyond operating temperature limits

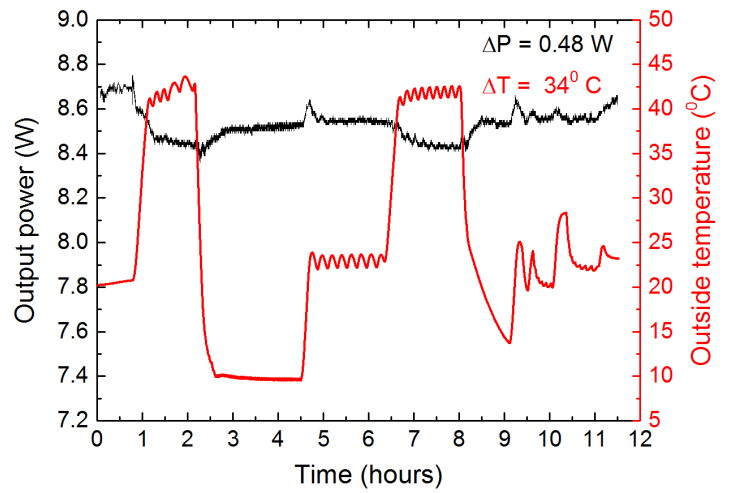

TETA-10 thermal stressing with chiller stabilization turned OFF. The test is used to show the rigidity of the TETA mechanical design and repeatability of output parameters after transportation or long off-duty periods

System controls

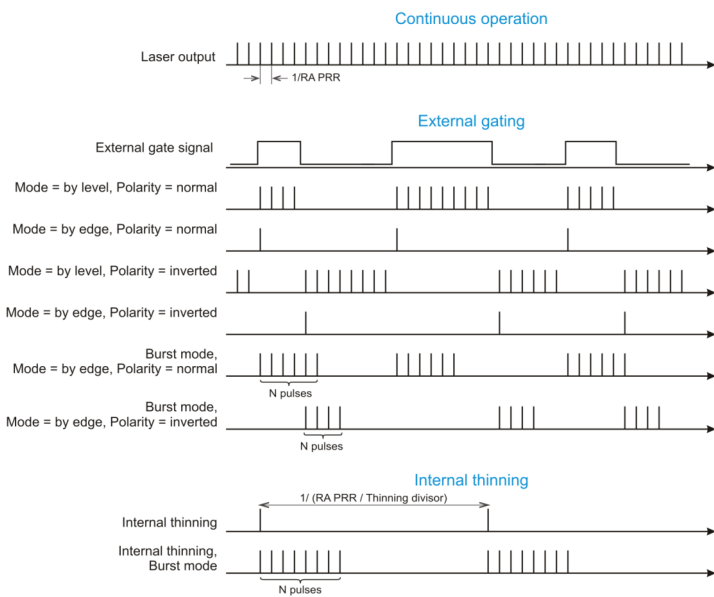

TETA output control modes overview

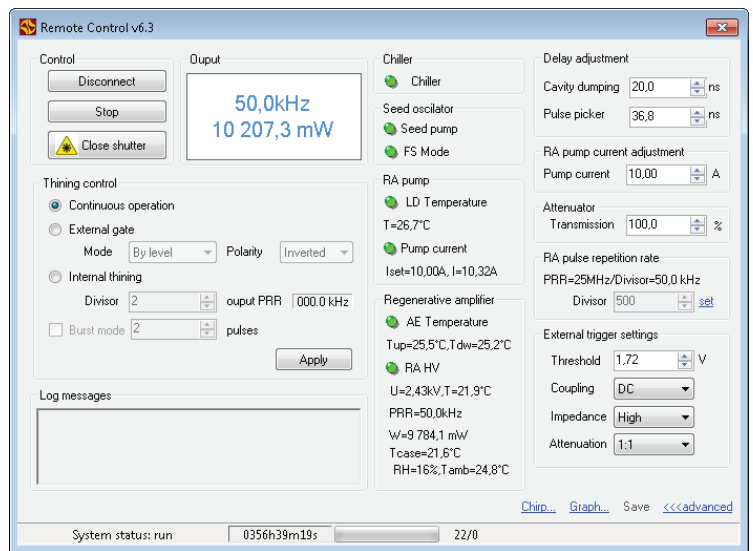

TETA remote control PC software

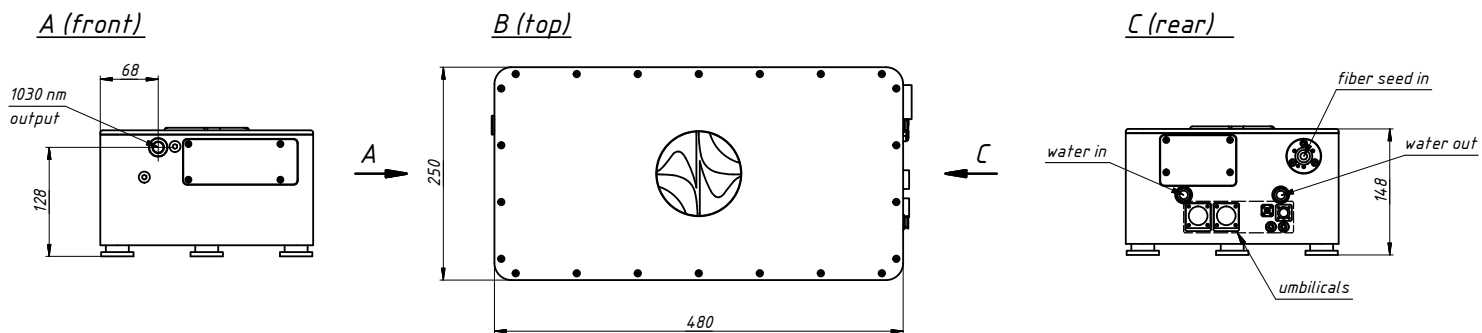

TETA-3-HE/-6/-10 laser head dimensions in mm (front, top and rear views)

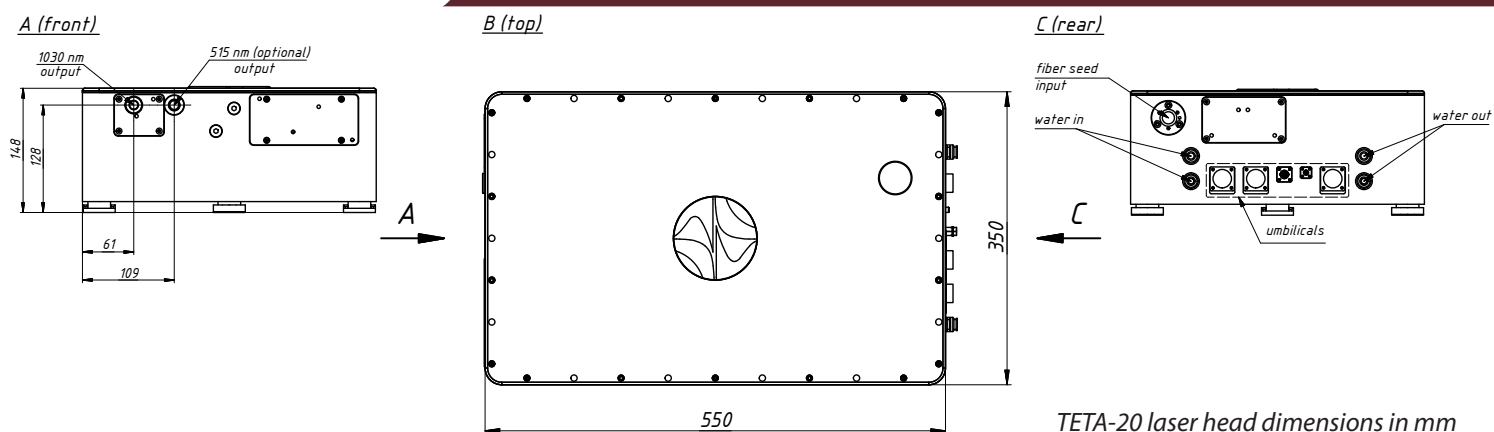

TETA-20 laser head dimensions in mm (front, top and rear views)

Applications

Material: Titanium alloy, thickness 2.5 mm.

Front surface:

Rear surface:

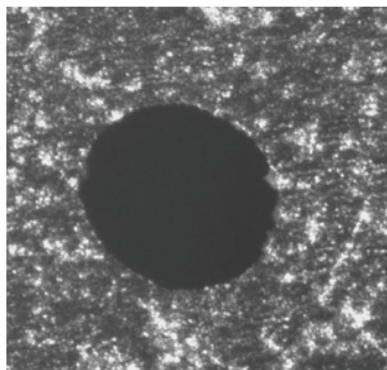
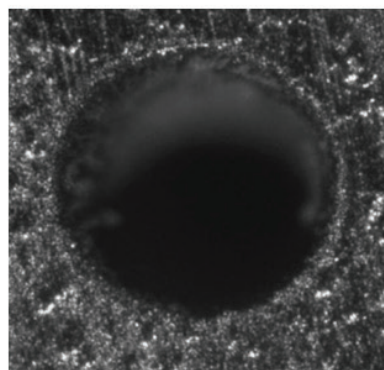

400-um hole drilling in 2.5 mm thick Ti alloy by TETA system

400 μm

1) Hole diameter 200 um

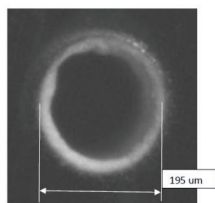
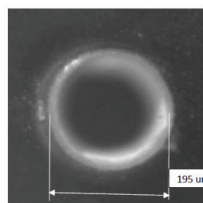

Figure 1. Frontal plate surface.

Figure 2. Rear plate surface.

Side view (machining progress left to right)

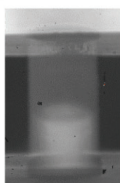
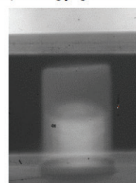
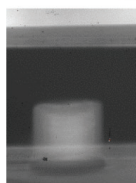

Figure 3. Side view 30%.

Figure 4. Side view 70%.

Figure 5. Side view 100%.

2) Hole diameter 300 um

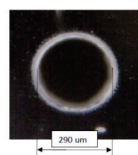
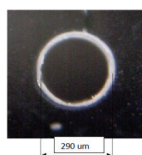

Figure 6. Frontal plate surface.

Figure 7. Rear plate surface.

3) Hole diameter 400 um

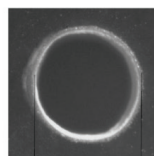
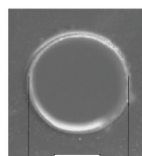

Figure 8. Frontal plate surface.

Figure 9. Rear plate surface.

Sapphire hole drilling in 440 um thick sapphire wafer by the TETA system